

# Four-axle, four-tank, Polish made 61m<sup>3</sup> railway wagon, discharge system: two side discharge at the bottom, with air supply to each tank

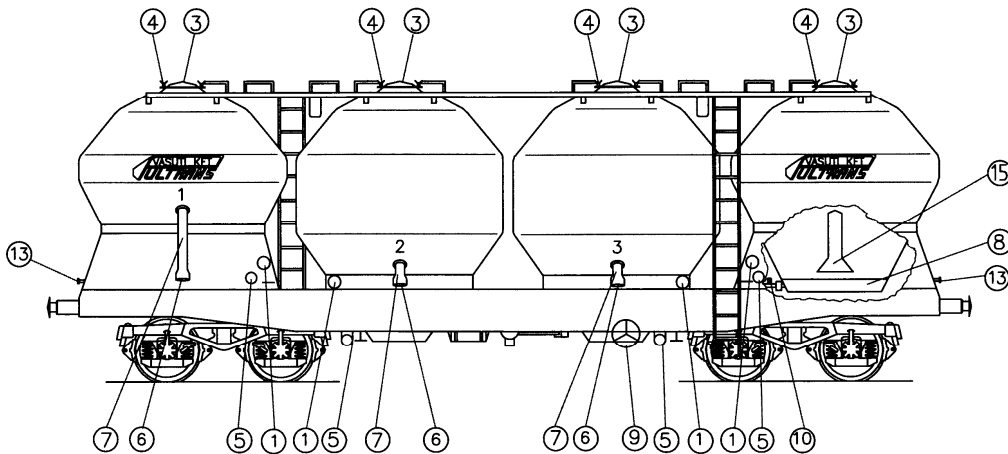

## Technical data

Maximum length:	14 040,0 mm
Maximum width:	3 100,0 mm
Maximum height:	4 224,0 mm
Weight (ca):	27,0 tons
Load capacity (ca):	53,0 tons
Cubic capacity:	2 x 12,5 + 2 x 18 m <sup>3</sup>
Total capacity:	61,0 m <sup>3</sup>
Maximum working pressure:	3,0 bar

## Loading limits

	A	B1	B2	C
S	37	43	45	53
120	00			

Capable of RIV traffic without restrictions

## Signs

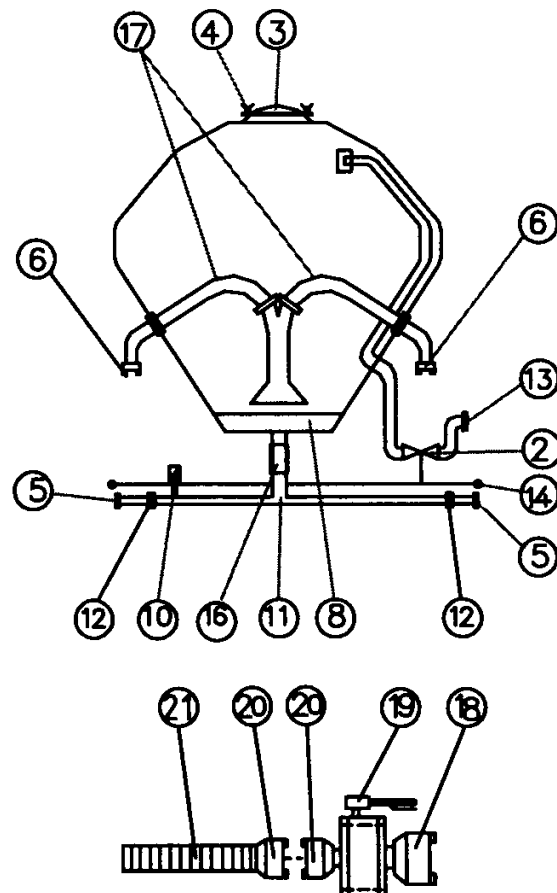

1. Manometer (pressure measuring device)
2. Air release valve
3. Top cover cap
4. Top cover screw
5. Diameter 52 mm (type C) air charging coupling with caps on both ends (DIN 14332,14307, ÖNORM F2131,MSZ 1057)  
Cap of air charging pipe (DIN 14332,14307, ÖNORM F2131,MSZ 1057)
6. Diameter 110 mm(Guillemin) material discharging pipe's coupling with cap (EN ISO 228-1)  
Cap of material discharging pipe (EN ISO 228-1)
7. Discharging pipe
8. Fluidising device containing textile filter
9. Handbrake
10. Safety disc
11. Pipe of discharging air
12. Back-blow valve
13. Air release pipe
14. Air release valve moving bars
15. Discharge pipe
16. Flexible pipe
17. Discharge pipes

### Optional transloading equipment:

18. Diameter 110 mm coupling (Guillemin)
19. Butterfly valve
20. Diameter 75 mm coupling (Type „B”)
21. Flexible material discharging pipe