

Two-axle, two-tank, Polish made railway wagon, discharge system: bottom discharge at the end of the wagon, with air supply to each tank

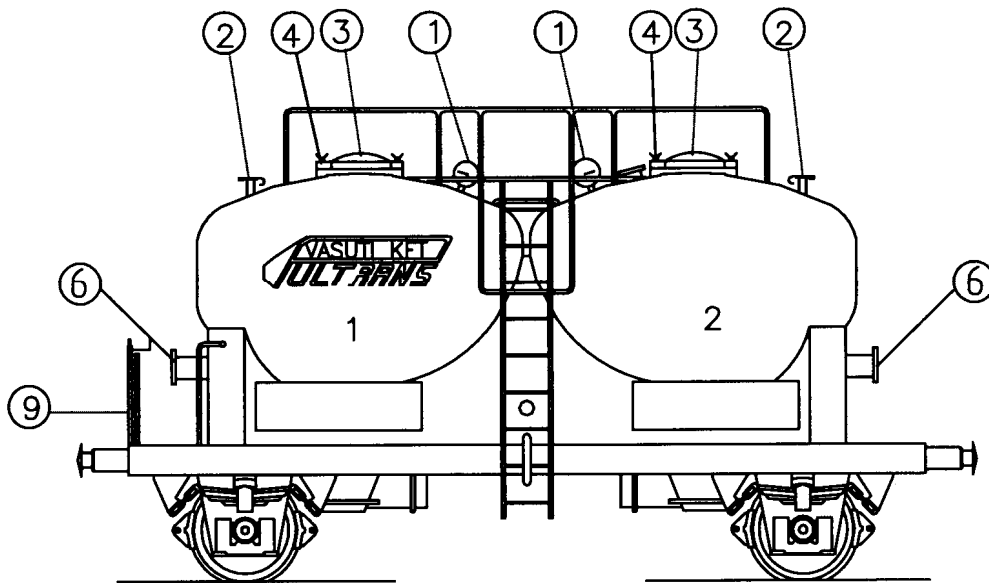

Technical data

Maximum length:	8 740,0 mm
Maximum width:	3 000,0 mm
Maximum height:	4 016,0 mm
Weight (ca):	13,0 tons
Load capacity (ca):	27,0 tons
Cubic capacity:	2 X 13,2 m ³
Total capacity:	26,4 m ³
Maximum working pressure:	3,0 bar

Loading limits

	A	B	C
S	19	23	27
120	00		

Capable of RIV traffic without restrictions

Signs

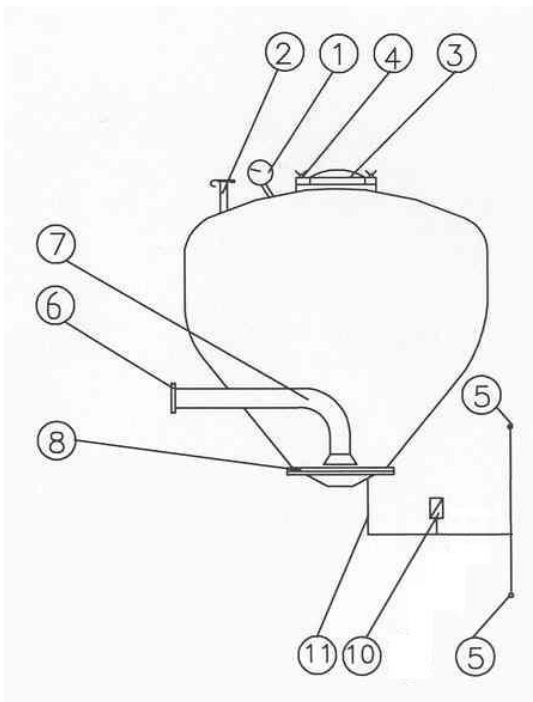

1. Manometer (pressure measuring device)
2. Air release valve
3. Top cover cap
4. Top cover screw
5. Diameter 52 mm (type C) air charging coupling with caps on both ends (DIN 14332,14307, ÖNORM F2131,MSZ 1057)
Cap of air charging pipe (DIN 14332,14307, ÖNORM F2131,MSZ 1057)
6. Diameter 110 mm(type A) material discharging pipe's coupling with cap (DIN 14303,ÖNORM F2120, F2129,MSZ 1057)
Cap of material discharging pipe (DIN 4303, ÖNORM F2120, F2129,MSZ 1057)
7. Discharging pipe
8. Fluidising device containing textile filter
9. Handbrake
10. Safety valve
11. Pipe of discharging air