

# Four-axle, Romanian made, pressure discharge railway wagon for carrying bulk powder materials

Discharge system: two side discharge at the bottom and equipped with supporting air

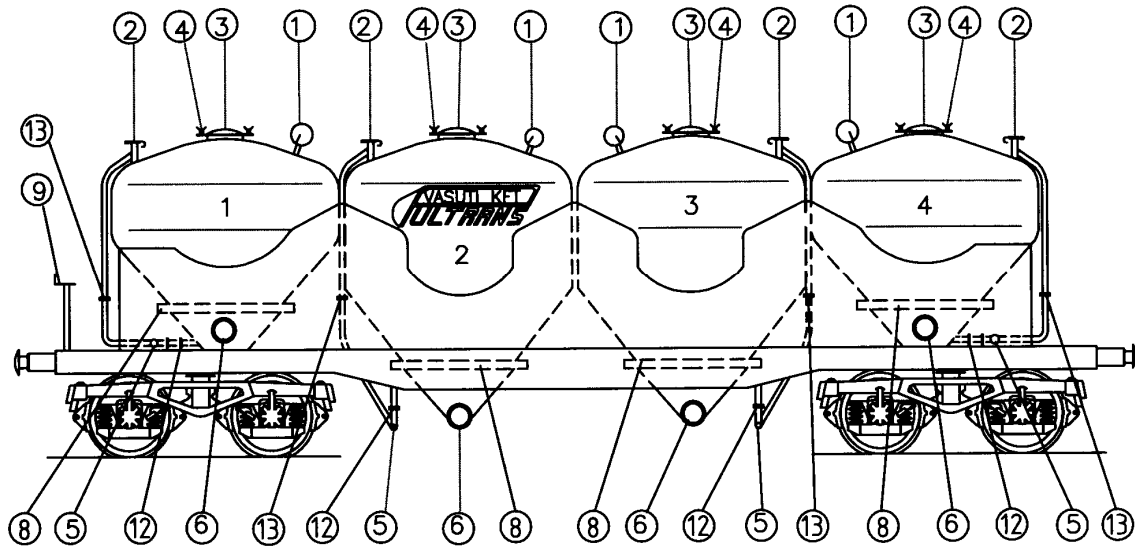

## Technical data

Maximum length:	14 040,0 mm
Maximum width:	2 980,0 mm
Maximum height:	4 247,0 mm
Weight (ca):	26,0 tons
Load capacity (ca):	54,0 tons
Cubic capacity:	2 x 9,2 + 2 x 14,3 m <sup>3</sup>
Total capacity:	47,0 m <sup>3</sup>
Maximum working pressure:	3,0 bar

## Loading limits

	A	B1	B2	C
S	38	44	46	54
120	00			

Capable of RIV traffic without restrictions.

## Signs

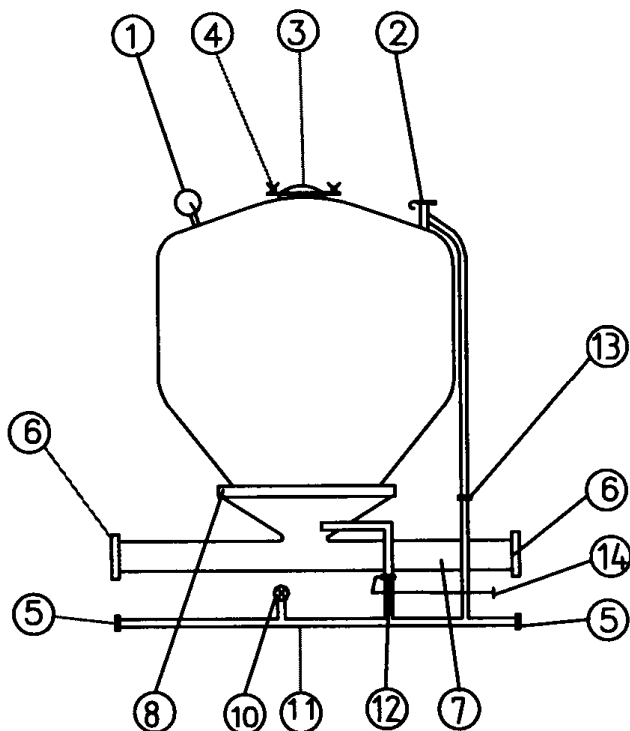

1. Manometer (pressure measuring device)
2. Air release valve
3. Top cover cap
4. Top cover screw
5. Diameter 52 mm (type C) air charging coupling with caps on both ends (DIN 14332,14307, ÖNORM F2131,MSZ 1057)  
Cap of air charging pipe (DIN 14332,14307, ÖNORM F2131,MSZ 1057)
6. Diameter 110 mm(type A) material discharging pipe's coupling with cap (DIN 14303,ÖNORM F2120, F2129,MSZ 1057)  
Cap of material discharging pipe (DIN 4303, ÖNORM F2120, F2129,MSZ 1057)
7. Discharging pipe
8. Fluidising device containing textile filter
9. Handbrake
10. Safety disc
11. Pipe of discharging air
12. Tap of discharging air
13. Tap of supporting air
14. Discharging air tap move bars (blue)